



February 7<sup>th</sup>, 2010

**18s Gold Tournament – 8:00am Start**

**Pool A**

1. Nebraska Elite L.O.D.
2. GI Islanders 18 Black
3. Nebraska Impact 181 Rage

**Pool B**

1. Premier 18 Gold
2. Omaha Wave 18 Kaiea
3. Lincoln MAGIC 18 Thunder

**Pool C**

1. GI Islanders 18 Purple
2. Nebraska Dominators 18 Red
3. Nebraska Jrs 181

**Court – Runza**

- |          |               |
|----------|---------------|
| 8:00 AM  | C1 vs C3 (C2) |
| 9:00 AM  | A1 vs A3 (A2) |
| 10:00 AM | A2 vs A3 (A1) |
| 11:00 AM | A1 vs A2 (A3) |
| 12:00 PM | C1 vs C2 (C3) |

**Court - Ameritas**

- |               |
|---------------|
| XXXXX         |
| B1 vs B3 (B2) |
| C2 vs C3 (C1) |
| B2 vs B3 (B1) |
| B1 vs B2 (B3) |

**Tournament Play**

**Court – Runza**

- |         |                              |
|---------|------------------------------|
| 1:00 PM | CH1) A2 vs C1 (B1)           |
| 2:00 PM | CH3) B1 vs wnr CH2 (Isr CH2) |
| 3:00 PM | CO1) A3 vs C3 (B3)           |
| 4:00 PM | CO2) B3 vs C3 (A3)           |
| 5:00 PM | CO3) A3 vs B3 (C3)           |

**Court - Ameritas**

- |   |
|---|
| CH2) B2 vs C2 (A1)                        |
| CH4) A1 vs wnr CH1 (Isr CH1)              |
| CH5) Isr CH1 vs Isr CH2 (wnr CH3)         |
| CH6) Isr CH3 vs Isr CH4 (Isr CH5)         |
| CH7) wnr CH3 vs wnr CH 4 (Isr CH6 or CH5) |

**CH = Championship Bracket CO = Consolation Bracket**

**Match Play:**

Pool play will be best 2 out of 3 sets to 25 points, starting at 0. Third game 0 – 15, if necessary.

**Warm-Ups:**

2:4:4 for all matches. Warm-ups will be 2 minutes of shared court time, followed by 4 min of hitting for the serving team and 4 min of hitting for the receiving team. Warm-ups can be shortened to 1-3-3 after each team's first match. The officiating team needs to start warm-ups immediately after the completion of the previous match. Please start the warm-ups before having a match-ending huddle. This will help all of us finish the tournament on schedule. Serving is to be completed during each team's court time. THERE IS NO SHARED SERVING.

**Tournament Play:**

The top 2 teams from each pool will advance to a championship bracket. The remaining teams will advance to a consolation bracket.

**All tournament matches will be best 2 out of 3 sets to 25 points, starting at 0. Third set 0-15, if necessary.**

If there are more teams tied by match record for advancing positions into the Championship tournament than there are available positions, ties will be broken using the playing scenarios on page 194 in the rulebook.

1. BEST SET (games) RECORD
2. HEAD TO HEAD COMPETITION
3. BEST SET RECORD PERCENTAGE (if applicable)  
(number of sets won divided by number of sets played)
4. TOTAL POINT DIFFERENTIAL
5. A COIN TOSS, IF NECESSARY

**T-SHIRTS WILL BE AWARDED TO FIRST PLACE TEAM.**

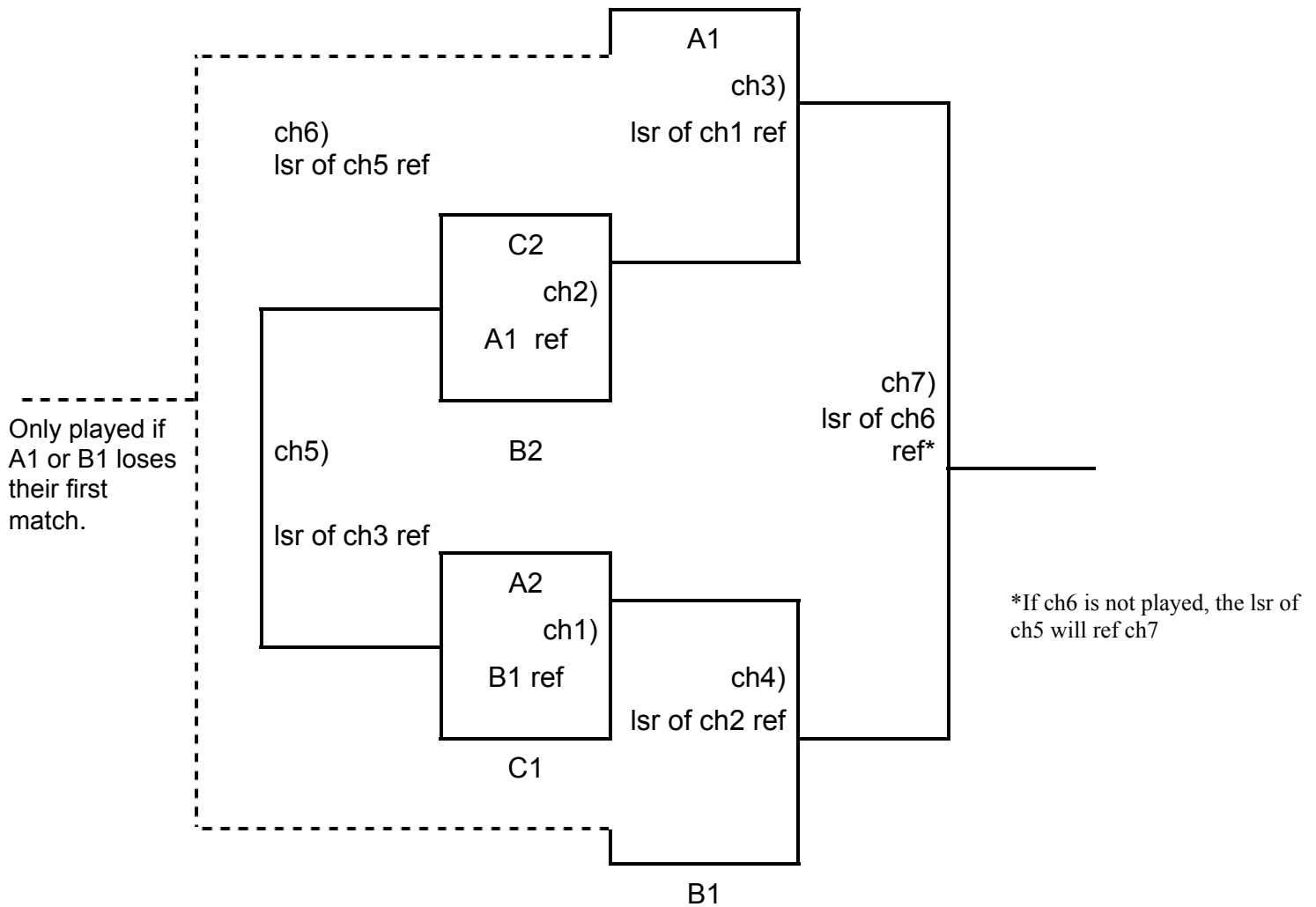

**Location:** The NVA training facility is located at the Abbott Sports Complex.

**Address:** 7600 N. 70<sup>th</sup> Street; Lincoln, NE 68517

**Tournament instructions on last page.**

### **Tournament Instructions:**

1. Each team must provide a team roster from the USA site to the tournament director at the check in table before your first match.
2. All athletes must put their gym bags and other belongings on the shelving provided. Bags left in the bleacher area will be asked to be moved.
3. Outside food, drink and coolers are NOT allowed in the facility. Concessions will be provided by Valentino's. Please leave all other food in your vehicle.
4. Bag chairs are allowed in the facility, in between the bleacher area only. The area in front of the bleachers must remain clear.
5. ABSOLUTELY NO FOOD IN EITHER GYM! NO FOOD AT THE SCORE TABLES!
6. NO GUM is allowed on the courts.

