



February 6th, 2010

12s Silver Tournament – 8:00am Start

Pool A

1. GI 12 Black
2. Lincoln YMCA Huskers
3. Bombers 121
4. Stanton Jrs 12

Pool B

1. GI Vikes 12-1
2. Nebraska ONE Phantoms
3. Lincoln YMCA Sparks

Pool C

1. Lincoln MAGIC 12 Stars
2. NVA 12 Black
3. Nebraska ONE Nitro

Court - Union Bank

- | | |
|----------|---------------|
| 8:00 AM | A1 vs A3 (A2) |
| 9:00 AM | A2 vs A4 (A1) |
| 10:00 AM | A1 vs A4 (A3) |
| 11:00 AM | A2 vs A3 (A4) |

Court - Midlands

- | |
|---------------|
| XXXXX |
| B1 vs B3 (B2) |
| B2 vs B3 (B1) |
| B1 vs B2 (B3) |

Court – Runza

- | |
|---------------|
| XXXXX |
| C1 vs C3 (C2) |
| C2 vs C3 (C1) |
| C1 vs C2 (C3) |

Tournament Play

Court - Union Bank

- | | |
|----------|-----------------------------------|
| 12:00 PM | CH1) #4 vs #5 (#1) |
| 1:00 PM | CH3) #1 vs wnr CH1 (Isr CH1) |
| 2:00 PM | CH5) Isr CH1 vs Isr CH2 (Isr CH3) |
| 3:00 PM | CH7) wnr CH3 vs wnr CH4 (Isr CH5) |

Court - Midlands

- | |
|-----------------------------------|
| CH2) #3 vs #6 (#2) |
| CH4) #2 vs wnr CH2 (Isr CH 2) |
| CO3) Isr CO1 vs Isr CO2 (Isr CH4) |
| CO4) wnr CO1 vs wnr CO2 (Isr CO3) |

Court - Runza

- | |
|-------------------------------------|
| CO1) #7 vs #10 (#8/#9) |
| CO2) #8 vs #9 (Isr CO1) |
| XXXXX |
| * CH6) Isr CH3 vs Isr CH4 (wnr CO3) |

** if necessary*

CH = Championship Bracket CO = Consolation Bracket

Match Play:

All pool play matches will be rally scoring, 2 sets to 25 points, starting at 7.

Warm-Ups:

2:4:4 for all matches. Warm-ups will be 2 minutes of shared court time, followed by 4 min of hitting for the serving team and 4 min of hitting for the receiving team. Warm-ups can be shortened to 1-3-3 after each team's first match. The officiating team needs to start warm-ups immediately after the completion of the previous match. Please start the warm-ups before having a match-ending huddle. This will help all of us finish the tournament on schedule. Serving is to be completed during each team's court time. THERE IS NO SHARED SERVING.

Tournament Play:

The top 2 teams from each pool will advance to a Championship tournament bracket. The remaining teams will advance to a Consolation tournament bracket

All tournament matches will be best 2 out of 3 sets to 25 points, starting at 7. Third set 0-15, if necessary.

T-SHIRTS WILL BE AWARDED TO FIRST PLACE TEAM.

THERE WILL BE NO PLAY-OFF GAMES. TEAMS WILL BE ASSIGNED TO TOURNAMENTS BY THE FOLLOWING METHOD:

1. BEST SET (games) RECORD
2. HEAD TO HEAD COMPETITION
3. BEST SET RECORD PERCENTAGE (if applicable)
(number of sets won divided by number of sets played)
4. TOTAL POINT DIFFERENTIAL
5. A COIN TOSS, IF NECESSARY

The top two teams from each pool will advance to a championship bracket. The remaining teams will compete in a consolation bracket.

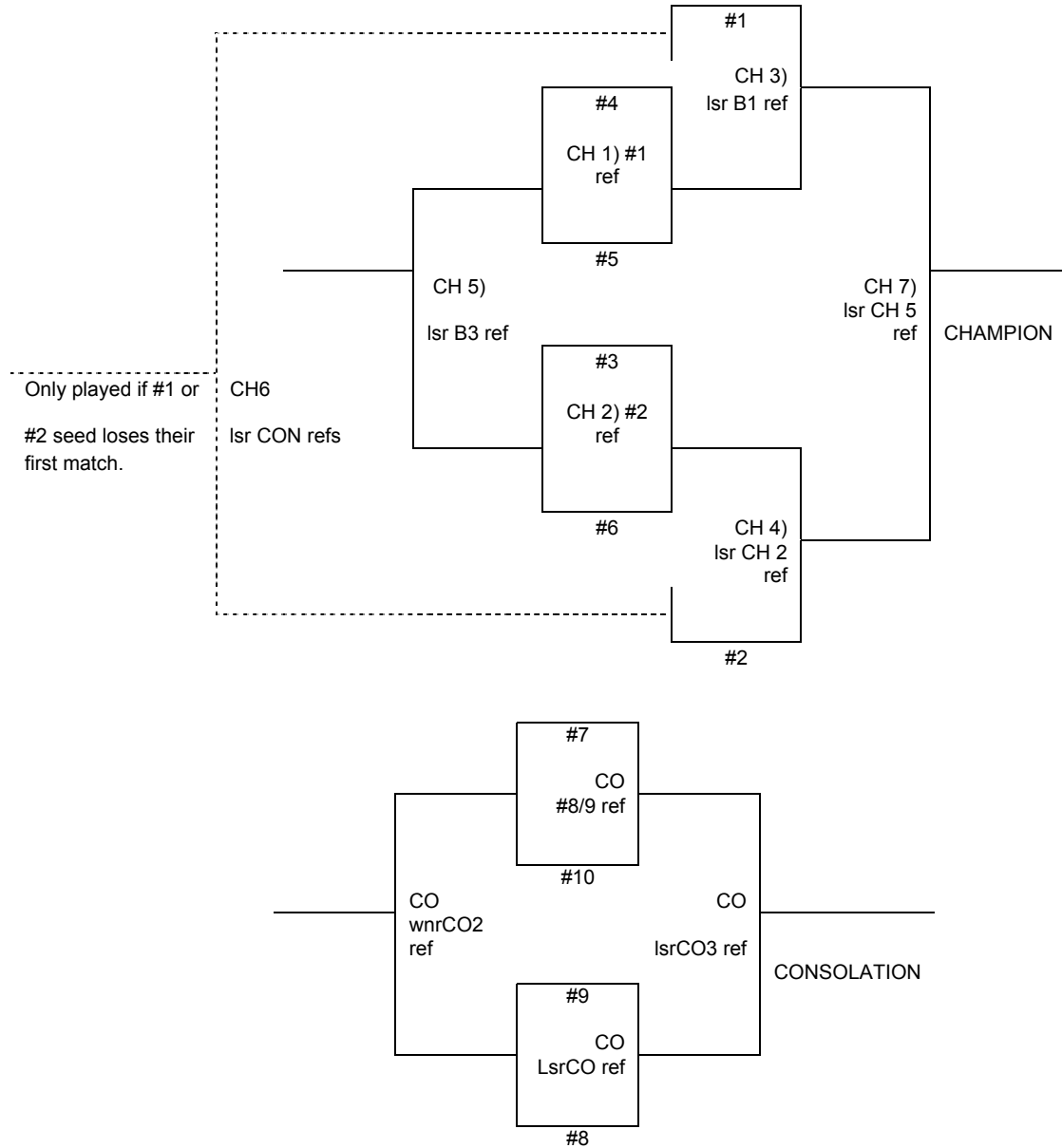

Location: The NVA training facility is located at the Abbott Sports Complex.
Address: 7600 N. 70th Street; Lincoln, NE 68517

Tournament Instructions:

1. Each team must provide a team roster from the USA site to the tournament director at the check in table before your first match.
2. All athletes must put their gym bags and other belongings on the shelving provided. Bags left in the bleacher area will be asked to be moved.
3. Outside food, drink and coolers are NOT allowed in the facility. Concessions will be provided by Valentino's. Please leave all other food in your vehicle.
4. Bag chairs are allowed in the facility, in between the bleacher area only. The area in front of the bleachers must remain clear.
5. ABSOLUTELY NO FOOD IN EITHER GYM! NO FOOD AT THE SCORE TABLES!
6. NO GUM is allowed on the courts.

